

Magic Tutorial #8: Circuit Extraction

Walter Scott

Special Studies Program
Lawrence Livermore National Laboratory
P.O. Box 808, L-270
Livermore, CA 94550

(Updated by others, too.)

This tutorial corresponds to Magic version 7.

Tutorials to read first:

Magic Tutorial #1: Getting Started
Magic Tutorial #2: Basic Painting and Selection
Magic Tutorial #4: Cell Hierarchies

Commands introduced in this tutorial:

`:extract`

Macros introduced in this tutorial:

(none)

Changes since Magic version 4:

New form of **:extract unique**
Path length extraction with **:extract length**
Accurate resistance extraction with **:extresis**
Extraction of well connectivity and substrate nodes
Checking for global net connectedness in *ext2sim* (1)
New programs: *ext2spice* (1) and *extcheck* (1)

1 Introduction

This tutorial covers the use of Magic’s circuit extractor. The extractor computes from the layout the information needed to run simulation tools such as *crystal* (1) and *esim* (1). This information includes the sizes and shapes of transistors, and the connectivity, resistance, and parasitic capacitance of nodes. Both capacitance to substrate and several kinds of internodal coupling capacitances are extracted.

Magic’s extractor is both incremental and hierarchical: only part of the entire layout must be re-extracted after each change, and the structure of the extracted circuit parallels the structure of the layout being extracted. The extractor produces a separate **.ext** file for each **.mag** file in a hierarchical design. This is in contrast to previous extractors, such as Mextra, which produces a single **.sim** file that represents the flattened (fully-instantiated) layout.

Sections 2 through 4 introduce Magic’s **:extract** command and some of its more advanced features. Section 5 describes what information actually gets extracted, and discusses limitations and inaccuracies. Section 6 talks about extraction styles. Although the hierarchical *ext* (5) format fully describes the circuit implemented by a layout, very few tools currently accept it. It is normally necessary to flatten the extracted circuit using one of the programs discussed in Section 7, such as *ext2sim* (1), *ext2spice* (1), or *extcheck* (1).

2 Basic Extraction

You can use Magic’s extractor in one of several ways. Normally it is not necessary to extract all cells in a layout. To extract only those cells that have changed since they were extracted, use:

```
:load root
:extract
```

The extractor looks for a **.ext** file for every cell in the tree that descends from the cell *root*. The **.ext** file is searched for in the same directory that contains the cell’s **.mag** file. Any cells that have been modified since they were last extracted, and all of their parents, are re-extracted. Cells having no **.ext** files are also re-extracted.

To try out the extractor on an example, copy all the **tut8x** cells to your current directory with the following shell commands:

```
cp ~cad/lib/magic/tutorial/tut8*.mag .
```

Start magic on the cell **tut8a** and type **:extract**. Magic will print the name of each cell (**tut8a**, **tut8b**, **tut8c**, and **tut8d**) as it is extracted. Now type **:extract** a second time. This time nothing gets printed, since Magic didn’t have to re-extract any cells. Now delete the piece of poly labelled “**delete me**” and type **:extract** again. This time, only the cell **tut8a** is extracted as it is the only one that changed. If you make a change to cell **tut8b** (do it) and then extract again, both **tut8b** and **tut8a** will be re-extracted, since **tut8a** is the parent of **tut8b**.

To force all cells in the subtree rooted at cell *root* to be re-extracted, use **:extract all**:

```
:loadroot
:extract all
```

Try this also on **tut8a**.

You can also use the **:extract** command to extract a single cell as follows:

:extract cell *name*

will extract just the selected (current) cell, and place the output in the file *name*. Select the cell **tut8b** (**tut8b_0**) and type **:extract cell differentFile** to try this out. After this command, the file **differentFile.ext** will contain the extracted circuit for the cell **tut8b**. The children of **tut8b** (in this case, the single cell **tut8d**) will not be re-extracted by this command. If more than one cell is selected, the upper-leftmost one is extracted.

You should be careful about using **:extract cell**, since even though you may only make a change to a child cell, all of its parents may have to be re-extracted. To re-extract all of the parents of the selected cell, you may use

:extract parents

Try this out with **tut8b** still selected. Magic will extract only the cell **tut8a**, since it is the only one that uses the cell **tut8b**. To see what cells would be extracted by **:extract parents** without actually extracting them, use

:extract showparents

Try this command as well.

3 Feedback: Errors and Warnings

When the extractor encounters problems, it leaves feedback in the form of stippled white rectangular areas on the screen. Each area covers the portion of the layout that caused the error. Each area also has an error message associated with it, which you can see by using the **:feedback** command. Type **:feedback help** while in Magic for assistance in using the **:feedback** command.

The extractor will always report extraction *errors*. These are problems in the layout that may cause the output of the extractor to be incorrect. The layout should be fixed to eliminate extraction errors before attempting to simulate the circuit; otherwise, the results of the simulation may not reflect reality.

Extraction errors can come from violations of transistor rules. There are two rules about the formation of transistors: no transistor can be formed, and none can be destroyed, as a result of cell overlaps. For example, it is illegal to have poly in one cell overlap diffusion in another cell, as that would form a transistor in the parent where none was present in either child. It is also illegal to have a buried contact in one cell overlap a transistor in another, as this would destroy the transistor. Violating these transistor rules will cause design-rule violations as well as extraction errors. These errors only relate to circuit extraction: the fabricated circuit may still work; it just won't be extracted correctly.

In general, it is an error for material of two types on the same plane to overlap or abut if they don't connect to each other. For example, in CMOS it is illegal for p-diffusion and n-diffusion to overlap or abut.

In addition to errors, the extractor can give *warnings*. If only warnings are present, the extracted circuit can still be simulated. By default, only some types of warnings are reported and displayed as feedback. To cause all warnings to be displayed, use

:extract warn all

The command

:extract warn *warning*

may be used to enable specific warnings selectively; see below. To cause no warnings to be displayed, or to disable display of a particular *warning*, use respectively

:extract warn no all or
:extract warn no *warning*

Three different kinds of warnings are generated. The **dup** warning checks to see whether you have two electrically unconnected nodes in the same cell labelled with the same name. If so, you are warned because the two unconnected nodes will appear to be connected in the resulting **.ext** file, which means that the extracted circuit would not represent the actual layout. This is bad if you're simulating the circuit to see if it will work correctly: the simulator will think the two nodes are connected, but since there's no physical wire between them, the electrons won't! When two unconnected nodes share the same label (name), the extractor leaves feedback squares over each instance of the shared name.

It's an excellent idea to avoid labelling two unconnected nodes with the same name within a cell. Instead, use the "correct" name for one of the nodes, and some mnemonic but textually distinct name for the other nodes. For example, in a cell with multiple power rails, you might use **Vdd!** for one of the rails, and names like **Vdd#1** for the others. As an example, load the cell **tut8e**. If the two nodes are connected in a higher-level cell they will eventually be merged when the extracted circuit is flattened. If you want to simulate a cell out of context, but still want the higher-level nodes to be hooked up, you can always create a dummy parent cell that hooks them together, either with wire or by using the same name for pieces of paint that lie over the terminals to be connected; see the cell **tut8f** for an example of this latter technique.

You can use the command

:extract unique

as an automatic means of labelling nodes in the manner described above. Run this command on the cell **tut8g**. A second version of this command is provided for compatibility with previous versions of Magic. Running

:extract unique #

will only append a unique numeric suffix to labels that end with a "#". Any other duplicate nodenames that also don't end in a "!" (the global nodename suffix as described in Section 5) are flagged by feedback.

A second type of warning, **fets**, checks to see whether any transistors have fewer diffusion terminals than the minimum for their types. For example, the transistor type “**dfet**” is defined in the **nmos** technology file as requiring two diffusion terminals: a source and a drain. If a capacitor with only one diffusion terminal is desired in this technology, the type **dcap** should be used instead. The **fets** warning is a consistency check for transistors whose diffusion terminals have been accidentally shorted together, or for transistors with insufficiently many diffusion terminals.

The third warning, **labels**, is generated if you violate the following guideline for placement of labels: Whenever geometry from two subcells abuts or overlaps, it’s a good idea to make sure that there is a label attached to the geometry in each subcell *in the area of the overlap or along the line of abutment*. Following this guideline isn’t necessary for the extractor to work, but it will result in noticeably faster extraction.

By default, the **dup** and **fets** warnings are enabled, and the **labels** warning is disabled.

Load the cell **tut8h**, expand all its children (**tut8i** and **tut8j**), and enable all extractor warnings with **:extract warn all**. Now extract **tut8h** and all of its children with **:extract**, and examine the feedback for examples of fatal errors and warnings.

4 Advanced Circuit Extraction

4.1 Lengths

The Magic extractor has a rudimentary ability to compute wire lengths between specific named points in a circuit. This feature is intended for use with technologies where the wire length between two points is more important than the total capacitance on the net; this may occur, for example, when extracting circuits with very long wires being driven at high speeds (*e.g.*, bipolar circuits). Currently, you must indicate to Magic which pairs of points are to have distances computed. You do this by providing two lists: one of *drivers* and one of *receivers*. The extractor computes the distance between each driver and each receiver that it is connected to.

Load the cell **tut8k**. There are five labels: two are drivers (**driver1** and **driver2**) and three are receivers (**receiverA**, **receiverB**, and **receiverC**). Type the commands:

```
:extract length driver driver1 driver2
:extract length receiver receiverA receiverB receiverC
```

Now enable extraction of lengths with **:extract do length** and then extract the cell (**:extract**). If you examine **tut8k.ext**, you will see several **distance** lines, corresponding to the driver-receiver distances described above. These distances are through the centerlines of wires connecting the two labels; where multiple paths exist, the shortest is used.

Normally the driver and receiver tables will be built by using **:source** to read a file of **:extract length driver** and **:extract length receiver** commands. Once these tables are created in Magic, they remain until you leave Magic or type the command

```
:extract length clear
```

which wipes out both tables.

Because extraction of wire lengths is *not* performed hierarchically, it should only be done in the root cell of a design. Also, because it’s not hierarchical, it can take a long time for long, complex wires such as power and ground nets. This feature is still experimental and subject to change.

4.2 Resistance

Magic provides for more accurate resistance extraction using the **:extresis** command. **:extresis** provides a detailed resistance/capacitance description for nets where parasitic resistance is likely to significantly affect circuit timing.

4.2.1 Tutorial Introduction

To try out the resistance extractor, load in the cell **tut8r**. Extract it using **:extract**, pause magic, and run **ext2sim** on the cell with the command

```
ext2sim tut8r
```

This should produce **tut8r.sim**, **tut8r.nodes**, and **tut8r.al**. Restart magic and type

```
:extresis tolerance 10  
:extresis
```

This will extract interconnect resistances for any net where the interconnect delay is at least one-tenth of the transistor delay. Magic should give the messages:

```
:extresis tolerance 10  
:extresis  
Adding net2; Tnew = 0.428038ns,Told = 0.3798ns  
Adding net1; Tnew = 0.529005ns,Told = 0.4122ns  
Total Nets: 7  
Nets extracted: 2 (0.285714)  
Nets output: 2 (0.285714)
```

These may vary slightly depending on your technology parameters. The **Adding [net]** lines describe which networks for which magic produced resistor networks. **Tnew** is the estimated delay on the net including the resistor parasitics, while **Told** is the delay without parasitics. The next line describes where magic thinks the slowest node in the net is. The final 3 lines give a brief summary of the total number of nets, the nets requiring extraction, and the number for which resistors were added to the output.

Running the resistance extractor also produced the file **cell.res.ext**. To produce a **.sim** file containing resistors, quit magic and type:

```
cat tut8r.ext tut8r.res.ext >tut8r.2.ext  
ext2sim -R -t! -t# tut8r.2
```

Comparing the two files, **tut8r.sim** and **tut8r.2.sim**, shows that the latter has the nodes **net1** and **net2** split into several parts, with resistors added to connect the new nodes together.

4.2.2 General Notes on using the resistance extractor

To use **:extresis**, the circuit must first be extracted using **:extract** and flattened using **ext2sim**. When **ext2sim** is run, do not use the **-t#** and **-t!** flags (i.e. don't trim the trailing **"#"** and **"!"** characters) or the **-R** flag because **:extresis** needs the **.sim** and **.ext** names to correspond exactly, and it needs the lumped resistance values that the extractor produces. Also, do not delete or rename the **.nodes** file; **:extresis** needs this to run. Once the **.sim** and **.nodes** files have been produced, type the command **:extresis** while running magic on the root cell. As the resistance extractor runs, it will identify which nets (if any) for which it is producing RC networks, and will identify what it thinks is the "slowest" point in the network. When it completes, it will print a brief summary of how many nets it extracted and how many required supplemental networks. The resistance networks are placed in the file **root.res.ext**. To produce a **.sim** file with the supplemental resistors, type **cat root.ext root.res.ext >newname.ext**, and then rerun **ext2sim** on the new file. During this second **ext2sim** run, the **-t** flag may be used.

Like extraction of wire lengths, resistance extraction is *not* performed hierarchically; it should only be done in the root cell of a design and can take a long time for complex wires.

4.2.3 Options, Features, Caveats and Bugs

The following is a list of command line options and the arguments that they take.

- **tolerance [value]**
This controls how large the resistance in a network must be before it is added to the output description. **value** is defined as the minimum ratio of transistor resistance to interconnect resistance that requires a resistance network. The default value is 1; values less than 1 will cause fewer resistors to be output and will make the program run faster, while values greater than 1 will produce more a larger, more accurate description but will run slower.
- **all**
Causes all nets in the circuit to be extracted; no comparison between transistor size and lumped resistance is performed. This option is not recommended for large designs.
- **simplify [on/off]**
Turns on/off the resistance network simplification routines. Magic normally simplifies the resistance network it extracts by removing small resistors; specifying this flag turns this feature off.
- **extout [on/off]**
Turns on and off the writing of the **root.res.ext** file. The default value is on.
- **lumped [on/off]**
Turns on the writing of **root.res.lump**. This file contains an updated value of the lumped resistance for each net that **:extresis** extracts.
- **silent [on/off]**
This option suppresses printing of the name and location of nets for which resistors are produced.

- **skip mask**
Specifies a list of layers that the resistance extractor is to ignore.
- **help**
Print brief list of options.

Attribute labels may also be used to specify certain extractor options. For a description of attributes and how they work, see tutorial 2. Following is a description of **:extresis** attributes.

- **res:skip@**
Causes this net to be skipped. This is useful for avoiding extraction of power supplies or other DC signals that are not labeled Vdd or GND.
- **res:force@**
Forces extraction of this net regardless of its lumped resistance value. Nets with both skip and force labels attached will cause the extractor to complain.
- **res:min=[value]@**
Sets the smallest resistor size for this net. The default value is the resistance of the largest driving transistor divided by the tolerance described above.
- **res:drive@** - Nets with no driving transistors will normally not be extracted. This option allows the designer to specify from where in the net the signal is driven. This is primarily useful when extracting subcells, where the transistors driving a given signal may be located in a different cell.

4.2.4 Technology File Changes

Certain changes must be made in the extract section of the technology file to support resistance extraction. These include the **fetresist** and **contact** lines, plus a small change to the fet line. Full details can be found in Magic Maintainer's Manual #2. The only thing to note is that, contrary to the documentation, the **gccap** and **gscap** parts of the fet line **MUST** be set; the resistance extractor uses them to calculate RC time constants for the circuit.

5 Extraction Details and Limitations

This section explores in greater depth what gets extracted by Magic, as well as the limitations of the circuit extractor. A detailed explanation of the format of the **.ext** files output by Magic may be found in the manual page *ext* (5). "Magic Maintainer's Manual #2: The Technology File" describes how extraction parameters are specified for the extractor.

5.1 Nodes

Magic approximates the pieces of interconnect between transistors as "nodes". A node is like an equipotential region, but also includes a lumped resistance and capacitance to substrate. Figure 1

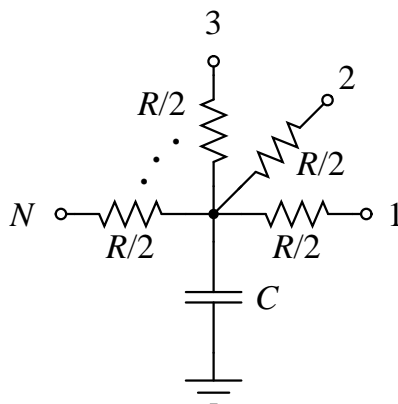

Figure 1: Each node extracted by Magic has a lumped resistance R and a lumped capacitance C to the substrate. These lumped values can be interpreted as in the diagram above, in which each device connected to the node is attached to one of the points $1, 2, \dots, N$.

shows how these lumped values are intended to be interpreted by the analysis programs that use the extracted circuit.

Each node in an extracted circuit has a name, which is either one of the labels attached to the geometry in the node if any exist, or automatically generated by the extractor. These latter names are always of the form $p_x.y\#$, where p , x , and y are integers, e.g., **3_104_17#**. If a label ending in the character “!” is attached to a node, the node is considered to be a “global”. Post-processing programs such as *ext2sim* (1) will check to ensure that nodes in different cells that are labelled with the same global name are electrically connected.

Nodes may have attributes attached to them as well as names. Node attributes are labels ending in the special character “@”, and provide a mechanism for passing information to analysis programs such as *crystal* (1). The man page *ext* (5) provides additional information about node attributes.

5.2 Resistance

Magic extracts a lumped resistance for each node, rather than a point-to-point resistance between each pair of devices connected to that node. The result is that all such point-to-point resistances are approximated by the worst-case resistance between any two points in that node.

By default, node resistances are approximated rather than computed exactly. For a node comprised entirely of a single type of material, Magic will compute the node’s total perimeter and area. It then solves a quadratic equation to find the width and height of a simple rectangle with this same perimeter and area, and approximates the resistance of the node as the resistance of this “equivalent” rectangle. The resistance is always taken in the longer dimension of the rectangle. When a node contains more than a single type of material, Magic computes an equivalent rectangle for each type, and then sums the resistances as though the rectangles were laid end-to-end.

This approximation for resistance does not take into account any branching, so it can be significantly in error for nodes that have side branches. Figure 2 gives an example. For global signal trees such as clocks or power, Magic’s estimate of resistance will likely be several times higher

than the actual resistance between two points.

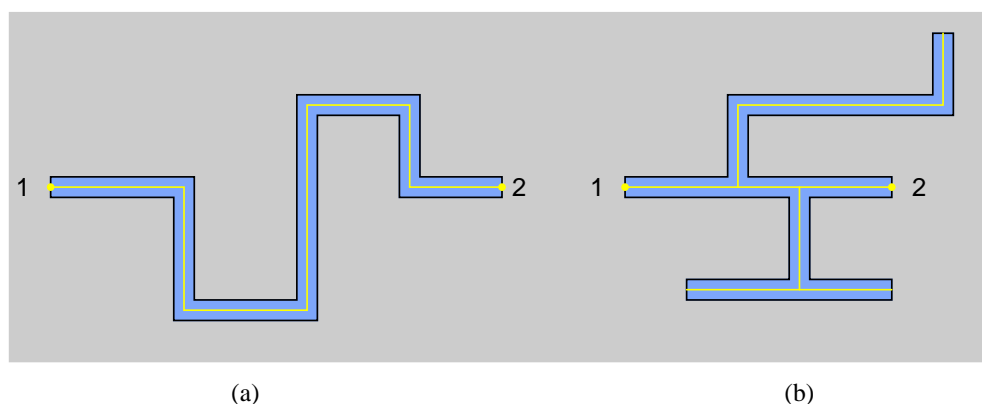

Figure 2: Magic approximates the resistance of a node by assuming that it is a simple wire. The length and width of the wire are estimated from the node’s perimeter and area. (a) For non-branching nodes, this approximation is a good one. (b) The computed resistance for this node is the same as for (a) because the side branches are counted, yet the actual resistance between points 1 and 2 is significantly less than in (a).

The approximated resistance also does not lend itself well to hierarchical adjustments, as does capacitance. To allow programs like **ext2sim** to incorporate hierarchical adjustments into a resistance approximation, each node in the **.ext** file also contains a perimeter and area for each “resistance class” that was defined in the technology file (see “Maintainer’s Manual #2: The Technology File,” and *ext* (5)). When flattening a circuit, **ext2sim** uses this information along with adjustments to perimeter and area to produce the value it actually uses for node resistance.

If you wish to disable the extraction of resistances and node perimeters and areas, use the command

:extract no resistance

which will cause all node resistances, perimeters, and areas in the **.ext** file to be zero. To re-enable extraction of resistance, use the command

:extract do resistance.

Sometimes it’s important that resistances be computed more accurately than is possible using the lumped approximation above. Magic’s **:extresist** command does this by computing explicit two-terminal resistors and modifying the circuit network to include them so it reflects more exactly the topology of the layout. See the section on **Advanced Extraction** for more details on explicit resistance extraction with **:extresist**.

5.3 Capacitance

Capacitance to substrate comes from two different sources. Each type of material has a capacitance to substrate per unit area. Each type of edge (i.e, each pair of types) has a capacitance to substrate per unit length. See Figure 3. The computation of capacitance may be disabled with

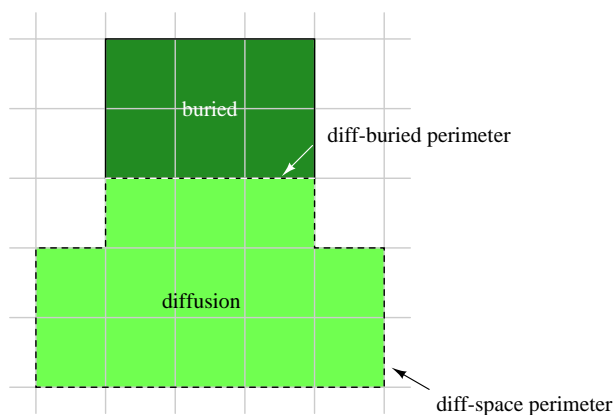

Figure 3: Each type of edge has capacitance to substrate per unit length. Here, the diffusion-space perimeter of 13 units has one value per unit length, and the diffusion-buried perimeter of 3 units another. In addition, each type of material has capacitance per unit area.

:extract no capacitance

which causes all substrate capacitance values in the `.ext` file to be zero. It may be re-enabled with

:extract do capacitance.

Internodal capacitance comes from three sources, as shown in Figure 4. When materials of two different types overlap, the capacitance to substrate of the one on top (as determined by the technology) is replaced by an internodal capacitance to the one on the bottom. Its computation may be disabled with

:extract no coupling

which will also cause the extractor to run 30% to 50% faster. Extraction of coupling capacitances can be re-enabled with

:extract do coupling.

Whenever material from two subcells overlaps or abuts, the extractor computes adjustments to substrate capacitance, coupling capacitance, and node perimeter and area. Often, these adjustments make little difference to the type of analysis you are performing, as when you wish only to compare netlists. Even when running Crystal for timing analysis, the adjustments can make less than a 5% difference in the timing of critical paths in designs with only a small amount of inter-cell overlap. To disable the computation of these adjustments, use

:extract no adjustment

which will result in approximately 50% faster extraction. This speedup is not entirely additive with the speedup resulting from **:extract no coupling**. To re-enable computation of adjustments, use **:extract do adjustment**.

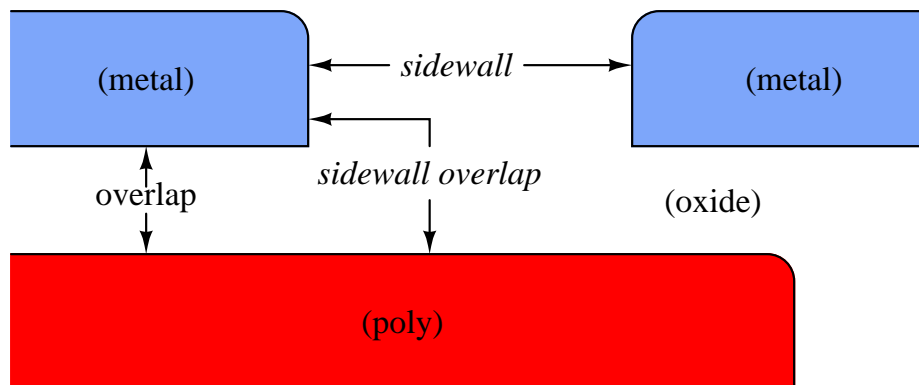

Figure 4: Magic extracts three kinds of internodal coupling capacitance. This figure is a cross-section (side view, not a top view) of a set of masks that shows all three kinds of capacitance. *Overlap* capacitance is parallel-plate capacitance between two different kinds of material when they overlap. *Sidewall* capacitance is parallel-plate capacitance between the vertical edges of two pieces of the same kind of material. *Sidewall overlap* capacitance is orthogonal-plate capacitance between the vertical edge of one piece of material and the horizontal surface of another piece of material that overlaps the first edge.

5.4 Transistors

Like the resistances of nodes, the lengths and widths of transistors are approximated. Magic computes the contribution to the total perimeter by each of the terminals of the transistor. See Figure 5. For rectangular transistors, this yields an exact L / W . For non-branching, non-rectangular transistors, it is still possible to approximate L / W fairly well, but substantial inaccuracies can be introduced if the channel of a transistor contains branches. Since most transistors are rectangular, however, Magic's approximation works well in practice.

Type	Loc	A P	Subs	Gate	Source	Drain
fet nfet	59 1 60 2	8 12	GND!	Mid2 4 N3	Out 4 0	Vss#0 4 0
fet nfet	36 1 37 2	8 12	Float	Mid1 4 N2	Mid2 4 0	Vss#0 4 0
fet nfet	4 1 5 2	8 12	Vss#0	In 4 N1	Mid1 4 0	Vss#0 4 0
fet pfet	59 25 60 26	8 12	Vdd!	Mid2 4 P3	Vdd#0 4 0	Out 4 0
fet pfet	36 25 37 26	8 12	VBias	Mid1 4 P2	Vdd#0 4 0	Mid2 4 0
fet pfet	4 25 5 26	8 12	Vdd#0	In 4 P1	Vdd#0 4 0	Mid1 4 0

Table 1: The transistor section of **tut8l.ext**.

In addition to having gate, source, and drain terminals, MOSFET transistors also have a substrate terminal. By default, this terminal is connected to a global node that depends on the transistor's type. For example, p-channel transistors might have a substrate terminal of **Vdd!**, while n-channel transistors would have one of **GND!**. However, when a transistor is surrounded by explicit "well" material (as defined in the technology file), Magic will override the default substrate terminal with the node to which the well material is connected. This has several advantages: it al-

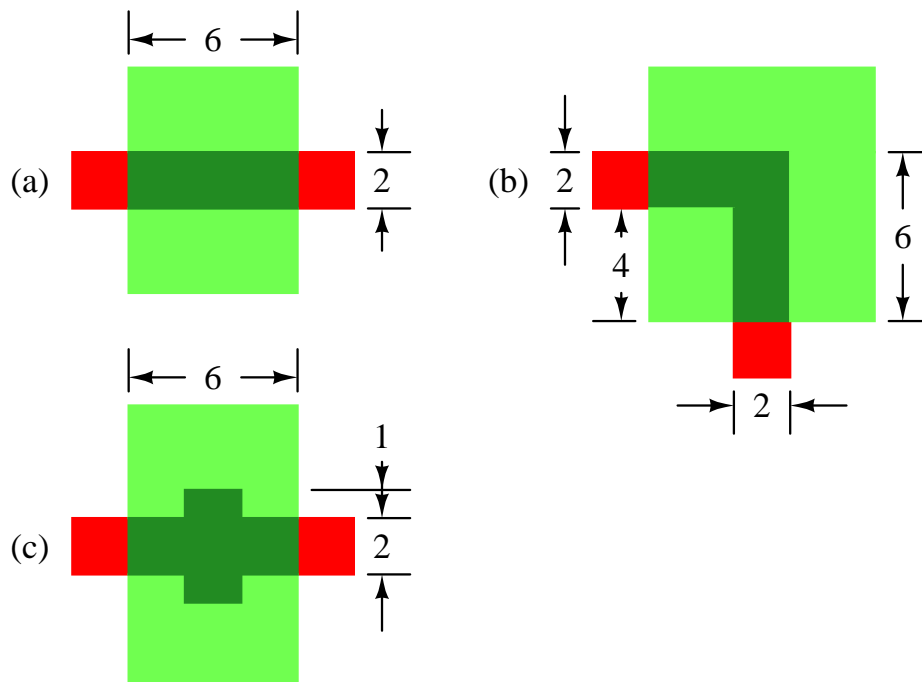

Figure 5: (a) When transistors are rectangular, it is possible to compute L/W exactly. Here $gateperim=4$, $srcperim=6$, $drainperim=6$, and $L/W = 2/6$. (b) The L/W of non-branching transistors can be approximated. Here $gateperim=4$, $srcperim=6$, $drainperim=10$. By averaging $srcperim$ and $drainperim$ we get $L/W = 2/8$. (c) The L/W of branching transistors is not well approximated. Here $gateperim=16$, $srcperim=2$, $drainperim=2$. Magic's estimate of L/W is $8/2$, whereas in fact because of current spreading, W is effectively larger than 2 and L effectively smaller than 8, so L/W is overestimated.

lows simulation of analog circuits in which wells are biased to different potentials, and it provides a form of checking to ensure that wells in a CMOS process are explicitly tied to the appropriate DC voltage.

Transistor substrate nodes are discovered by the extractor only if the transistor and the overlapping well layer are in the same cell. If they appear in different cells, the transistor's substrate terminal will be set to the default for the type of transistor.

Load the cell **tut8l**, extract it, and look at the file **tut8l.ext**. Table 1 shows the lines for the six transistors in the file. You'll notice that the substrate terminals (the *Subs* column) for all transistors are different. Since each transistor in this design has a different gate attribute attached to it (shown in bold in the table, e.g., **N1**, **P2**, etc), we'll use them in the following discussion.

The simplest two transistors are **N3** and **P3**, which don't appear in any explicitly drawn wells. The substrate terminals for these are **GND!** and **Vdd!** respectively, since that's what the technology file says is the default for the two types of transistors. **N1** and **P1** are standard transistors that lie in wells tied to the ground and power rails, labelled in this cell as **Vss#0** and **Vdd#0** respectively. (They're not labelled **GND!** and **Vdd!** so you'll see the difference between **N1** and **N3**). **P2** lies in a well that is tied to a different bias voltage, **VBias**, such as might occur in an analog design. Finally, **N2** is in a well that isn't tied to any wire. The substrate node appears as **Float** because

that's the label that was attached to the well surrounding **N2**.

The ability to extract transistor substrate nodes allows you to perform a simple check for whether or not transistors are in properly connected (*e.g.*, grounded) wells. In a p-well CMOS process, for example, you might set the default substrate node for n-channel transistors to be some distinguished global node other than ground, *e.g.*, **NSubstrateNode!**. You could then extract the circuit, flatten it using *ext2spice* (1) (which preserves substrate nodes, unlike *ext2sim* (1) which ignores them), and look at the substrate node fields of all the n-channel transistors: if there were any whose substrate nodes weren't connected to **GND!**, then these transistors appear either outside of any explicit well (their substrate nodes will be the default of **NSubstrateNode**), or in a well that isn't tied to **GND!** with a substrate contact.

6 Extraction styles

Magic usually knows several different ways to extract a circuit from a given layout. Each of these ways is called a *style*. Different styles can be used to handle different fabrication facilities, which may differ in the parameters they have for parasitic capacitance and resistance. For a scalable technology, such as the default **scmos**, there can be a different extraction style for each scale factor. The exact number and nature of the extraction styles is described in the technology file that Magic reads when it starts. At any given time, there is one current extraction style.

To print a list of the extraction styles available, type the command

```
:extract style.
```

The **scmos** technology currently has the styles **lambda=1.5**, **lambda=1.0**, and **lambda=0.6**, though this changes over time as technology evolves. To change the extraction style to *style*, use the command

```
:extract stylestyle
```

Each style has a specific scale factor between Magic units and physical units (*e.g.*, microns); you can't use a particular style with a different scale factor. To change the scalefactor, you'll have to edit the appropriate style in the **extract** section of the technology file. This process is described in "Magic Maintainer's Manual #2: The Technology File."

7 Flattening Extracted Circuits

Unfortunately, very few tools exist to take advantage of the *ext* (5) format files produced by Magic's extractor. To use these files for simulation or timing analysis, you will most likely need to convert them to a flattened format, such as *sim* (5) or *spice* (5).

There are several programs for flattening *ext* (5) files. *Ext2sim* (1) produces *sim* (5) files suitable for use with *crystal* (1), *esim* (1), or *rsim* (1). *Ext2spice* (1) is used to produce *spice* (5) files for use with the circuit-level simulator *spice* (1). Finally, *extcheck* (1) can be used to perform connectivity checking and will summarize the number of flattened nodes, transistors, capacitors, and resistors in a circuit. All of these programs make use of a library known as *extflat* (3), so the conventions for

each and the checks they perform are virtually identical. The documentation for *extcheck* covers the options common to all of these programs.

To see how *ext2sim* works, load the cell **tut8n** and expand all the **tutm** subcells. Notice how the **GND!** bus is completely wired, but the **Vdd!** bus is in three disconnected pieces. Now extract everything with **:extract**, then exit Magic and run **ext2sim tut8n**. You'll see the following sort of output:

```
*** Global name Vdd!  not fully connected:
One portion contains the names:
    left/Vdd!
The other portion contains the names:
    center/Vdd!
I'm merging the two pieces into a single node, but you
should be sure eventually to connect them in the layout.

*** Global name Vdd!  not fully connected:
One portion contains the names:
    left/Vdd!
    center/Vdd!
The other portion contains the names:
    right/Vdd!
I'm merging the two pieces into a single node, but you
should be sure eventually to connect them in the layout.

Memory used:  56k
```

The warning messages are telling you that the global name **Vdd!** isn't completely wired in the layout. The flattener warns you, but goes ahead and connects the pieces together anyway to allow you to simulate the circuit as though it had been completely wired. The output of *ext2sim* will be three files: **tut8n.sim**, **tut8n.al**, and **tut8n.nodes**; see *ext2sim* (1) or *sim* (5) for more information on the contents of these files. “**Magic Tutorial #11: Using RSIM with Magic**” explains how to use the output of *ext2sim* with the switch-level simulator, *rsim* (1).